

FRENCH FITNESS

FF-FL30

FRENCH FITNESS FL30 FREEWEIGHT
CORNER LEVERAGE GYM (NEW)

ASSEMBLY MANUAL



STATIONS INCLUDED

- Lat Pulldown (Tricep Extensions and Lat Pulldowns)
- Low Pulley (Seated Rows, Biceps, Abdominal, Leg Raises, Lat Raises, Upright Rows)
- Main Station (Squats + Multi Shoulder + Chest Press)
- -15 to 85 Degree Adjustable Bench
- Preacher Curl
- Leg Ext / Adjustable Multi Bench

TECH SPECS

- Dimensions: 103"L x 49.25"W x 83"H
- Length Measurements
 - 49.25"L Base Only
 - 55"L Base + Handles (Main Frame)
 - 82.5"L to 95"L - Main Frame w/Bench + Preacher Curl
 - 91"L to 103.5"L - Main Frame w/Bench + Leg Extension
 - 106-108"L: Full Machine w/Leg Ext in Motion

WARRANTY

- **10 Years Parts, 1 Year Labor (Home)**
- **California Residents see Prop 65 WARNING**

TABLE OF CONTENTS

MAIN STATION ASSEMBLY	4
ADJUSTABLE MULTI BENCH.....	7

MAIN STATION ASSEMBLY

Step 1

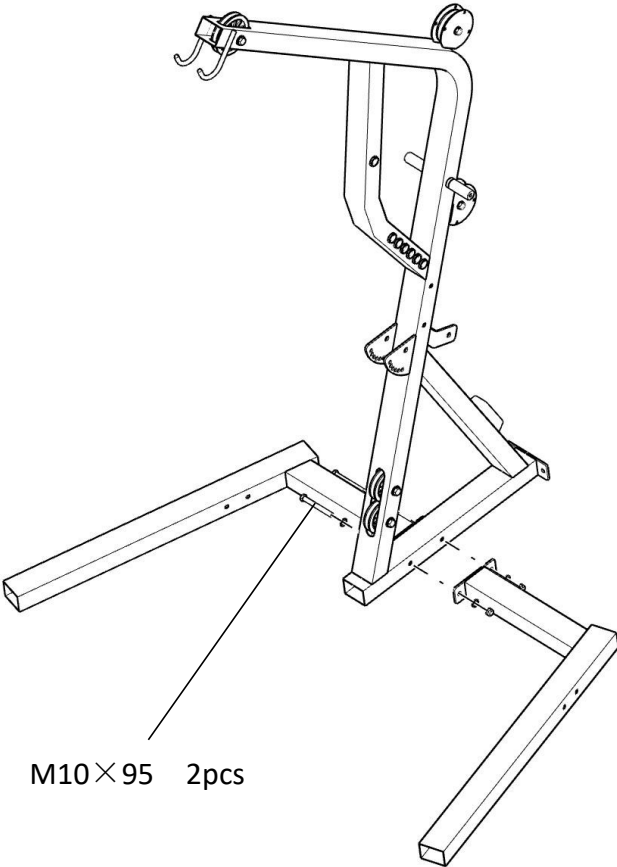

Step 2

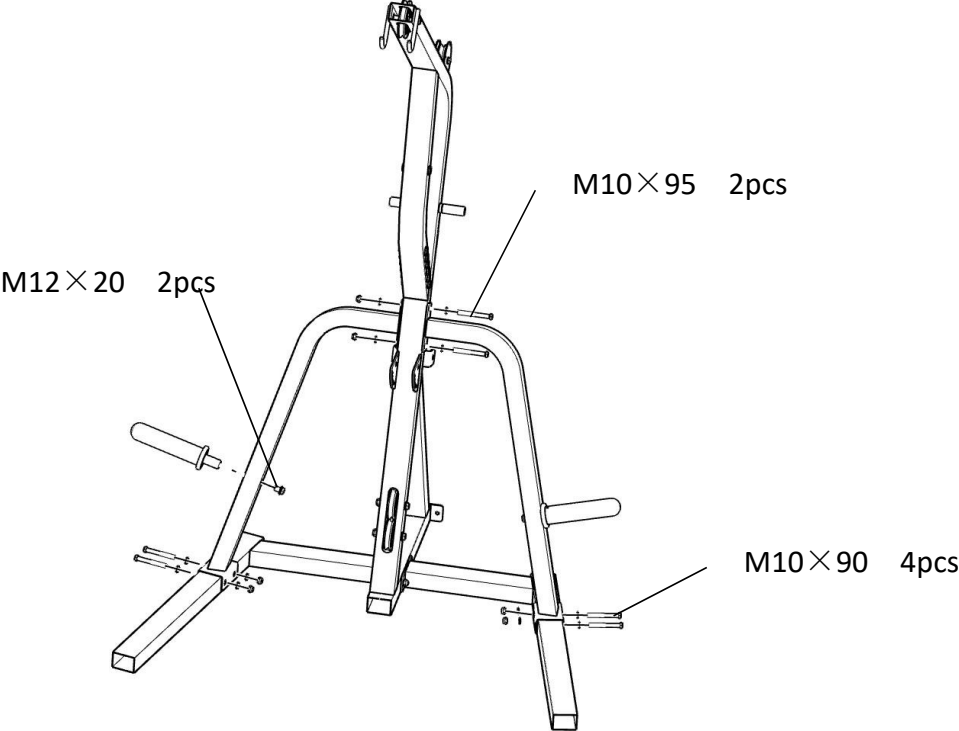

MAIN STATION ASSEMBLY

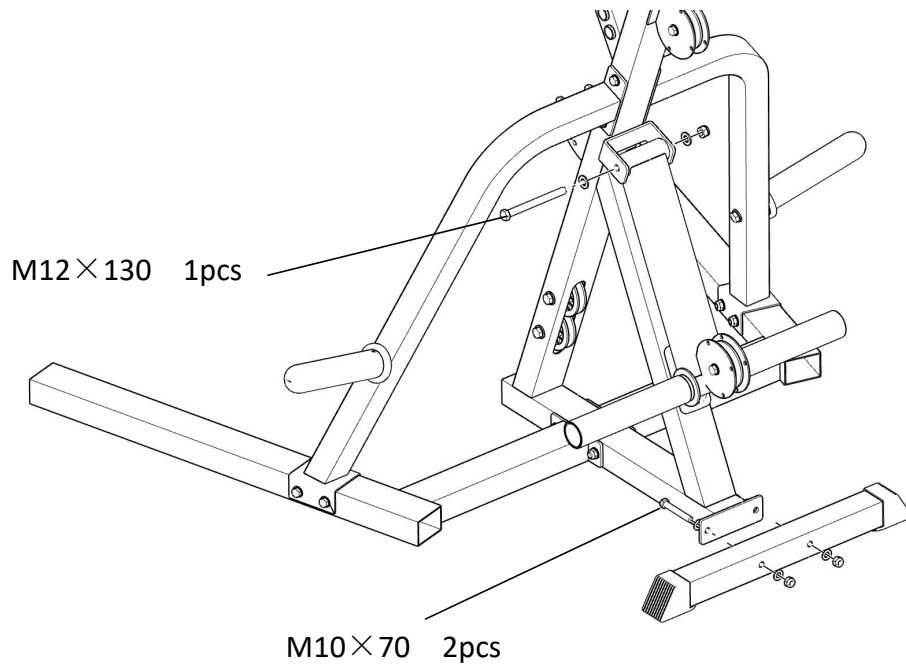

Step 4

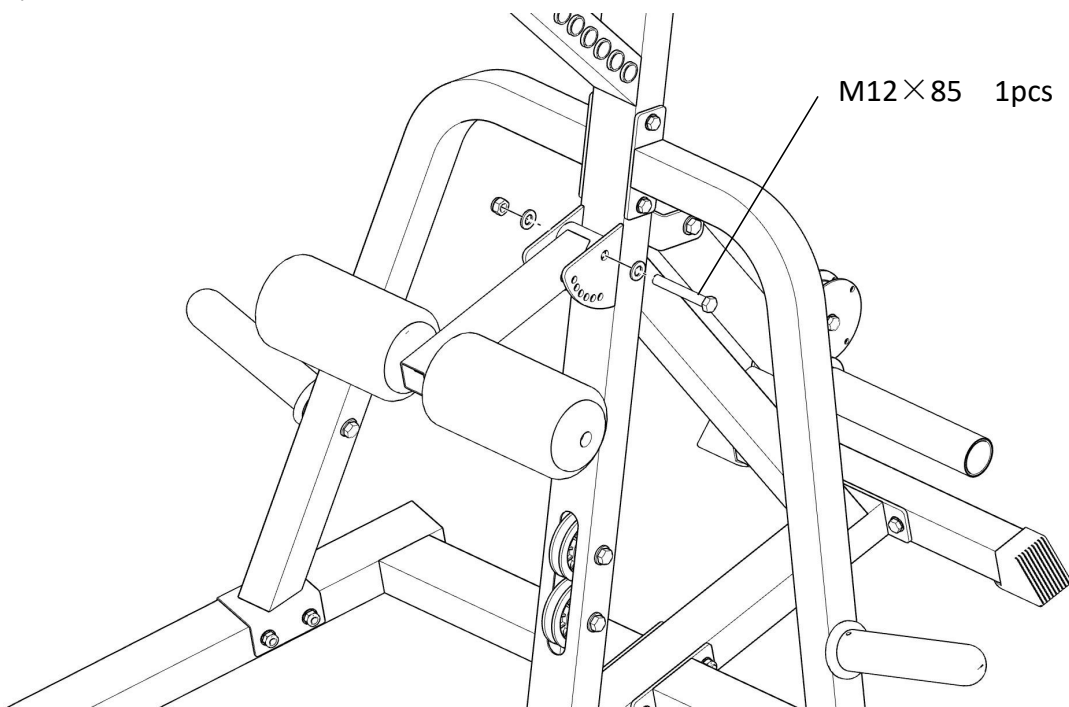

MAIN STATION ASSEMBLY

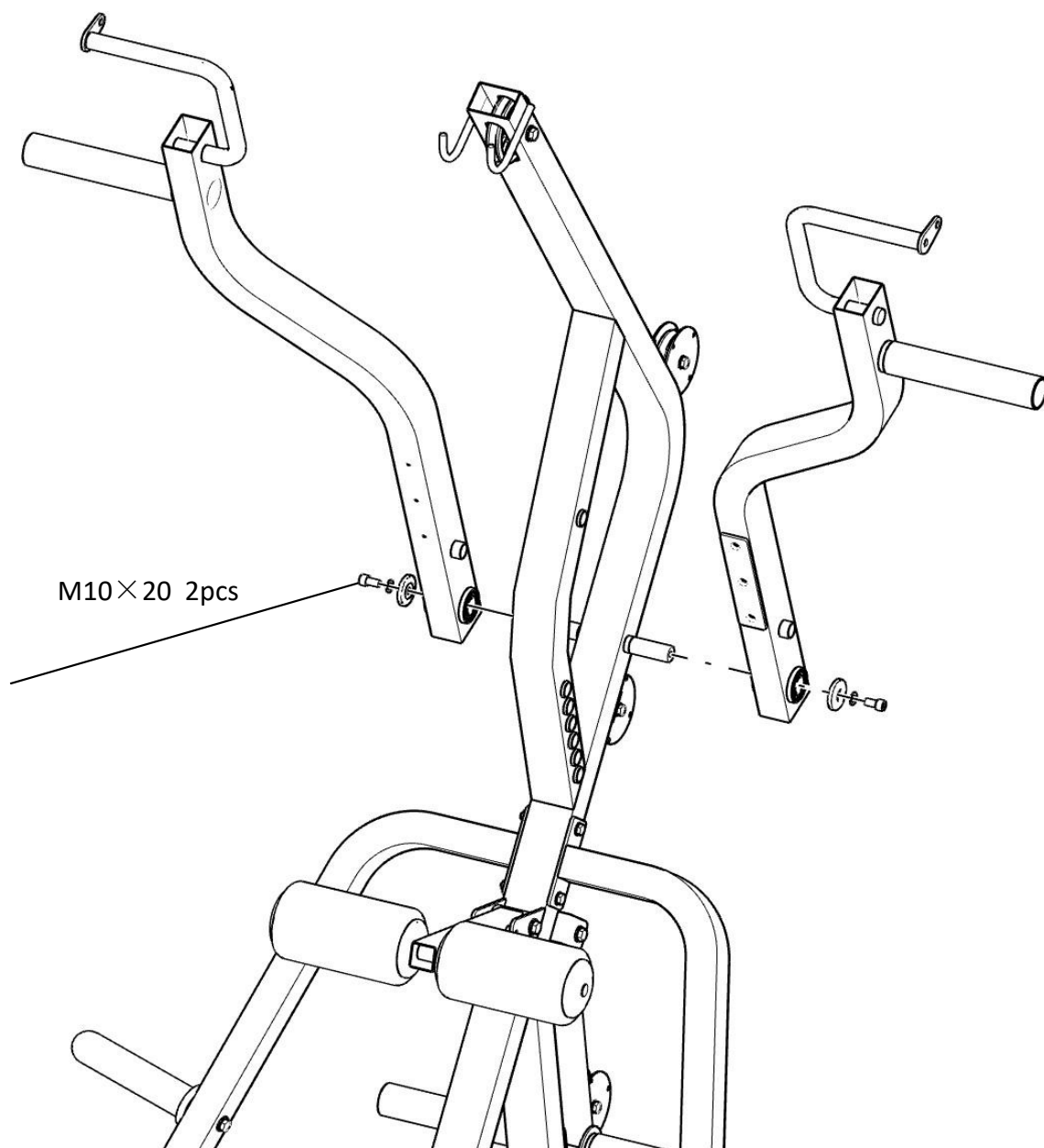

FRENCH FITNESS

ADJUSTABLE MULTI BENCH



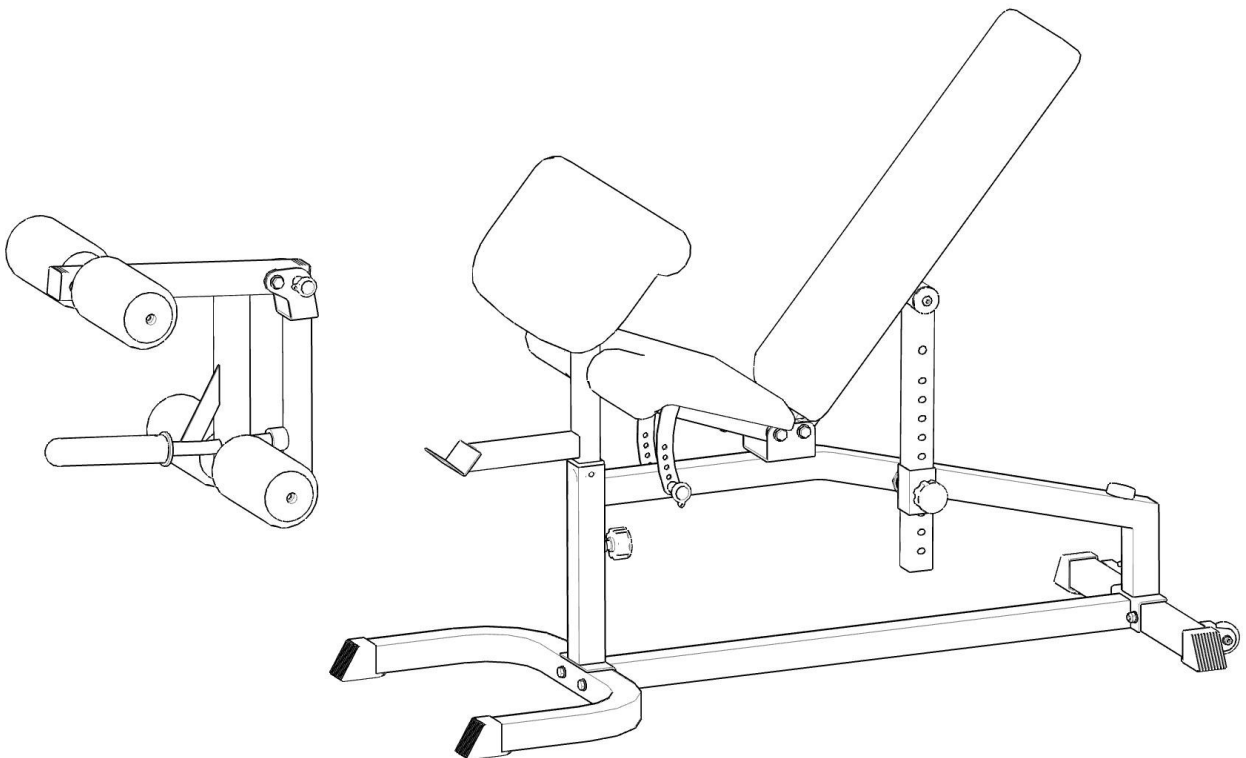







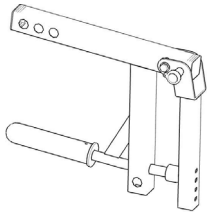
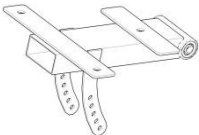
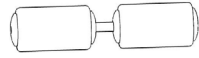
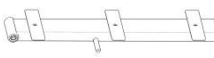
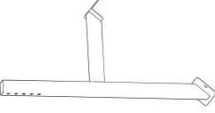
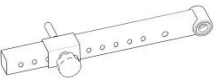
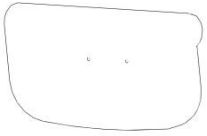

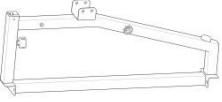
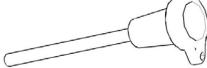

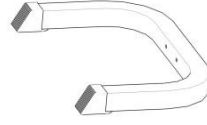
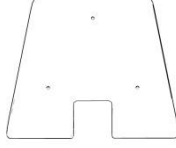
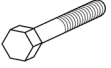
ASSEMBLY MANUAL

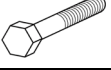

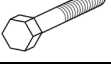
NOTE:

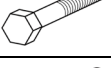
Please do not tighten all the screws at the beginning, Wait until all the parts are installed tightening all the screws.

PARTS LIST

NO.	Figure		QTY	NO.	Figure		QTY
1			1	8			1
2			2	9			1
3			1	10			1
4			1	11			2
5			1	12			2
6			1	13			1
7			1	14			1
15		M6X25	4	20		M6	8
16		M6X60	4	21		M10	10
17		M10*20	2	22		M12	4
18		M10X70	4	23		M10	4
19		M12X130	2	24		M10	2

ASSEMBLY STEPS

Figure 1

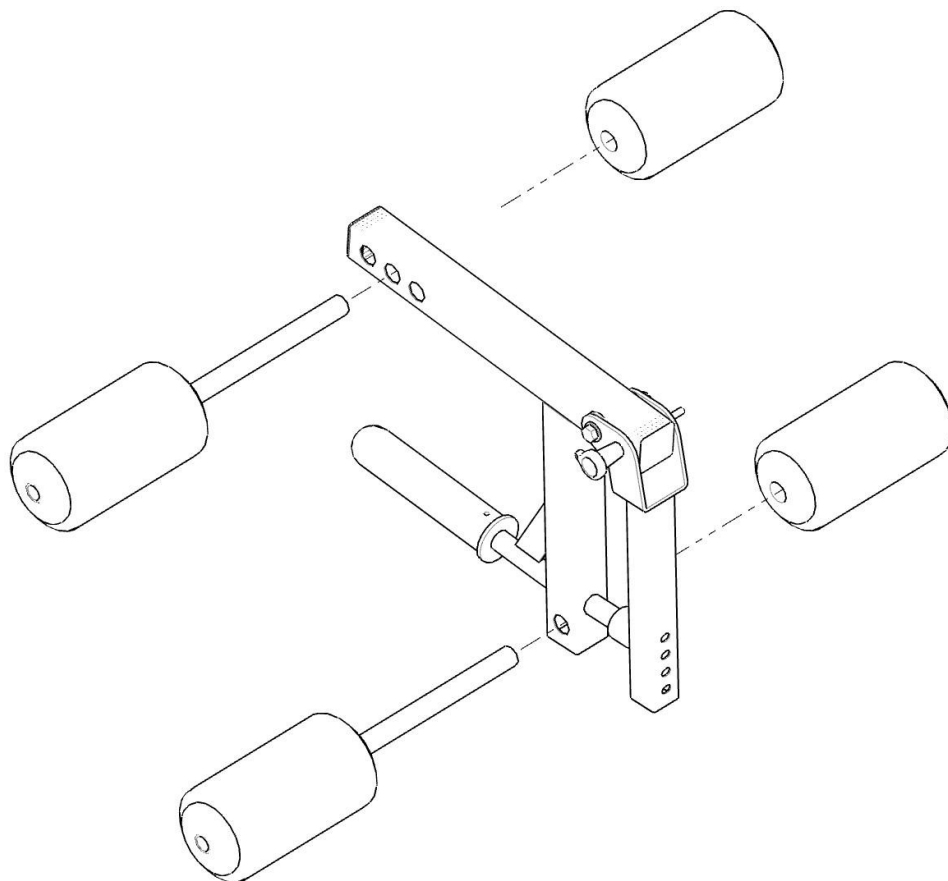



Step 1

As shown in Figure 1, Assemble part 1 and part 2 .

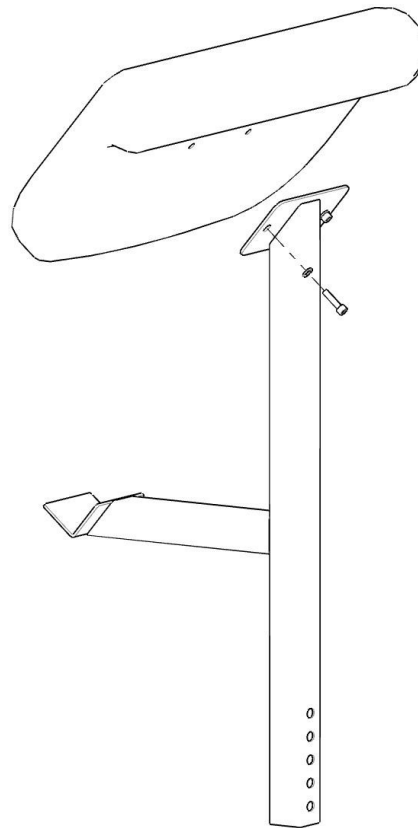
Figure 10

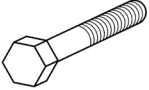

Step 2



	
M6*25 -----2pcs	M6----- 2pcs

As shown in Figure 2, part 4 is assembled onto part 3 using bolts and gaskets.

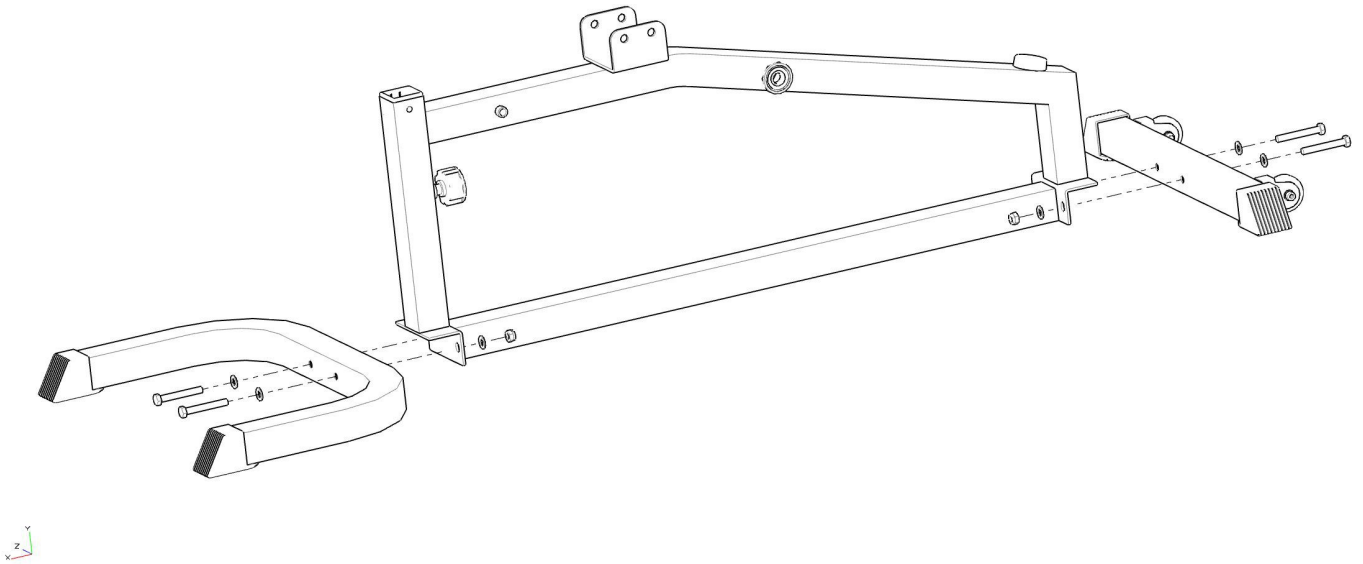
Figure 3

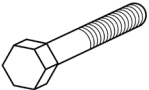

Step 3



	
M10*70 ----- 4pcs	M10 ----- 8pcs

As shown in Figure 3, part 6 and part 7 are assembled onto part 5 using bolts and gaskets.

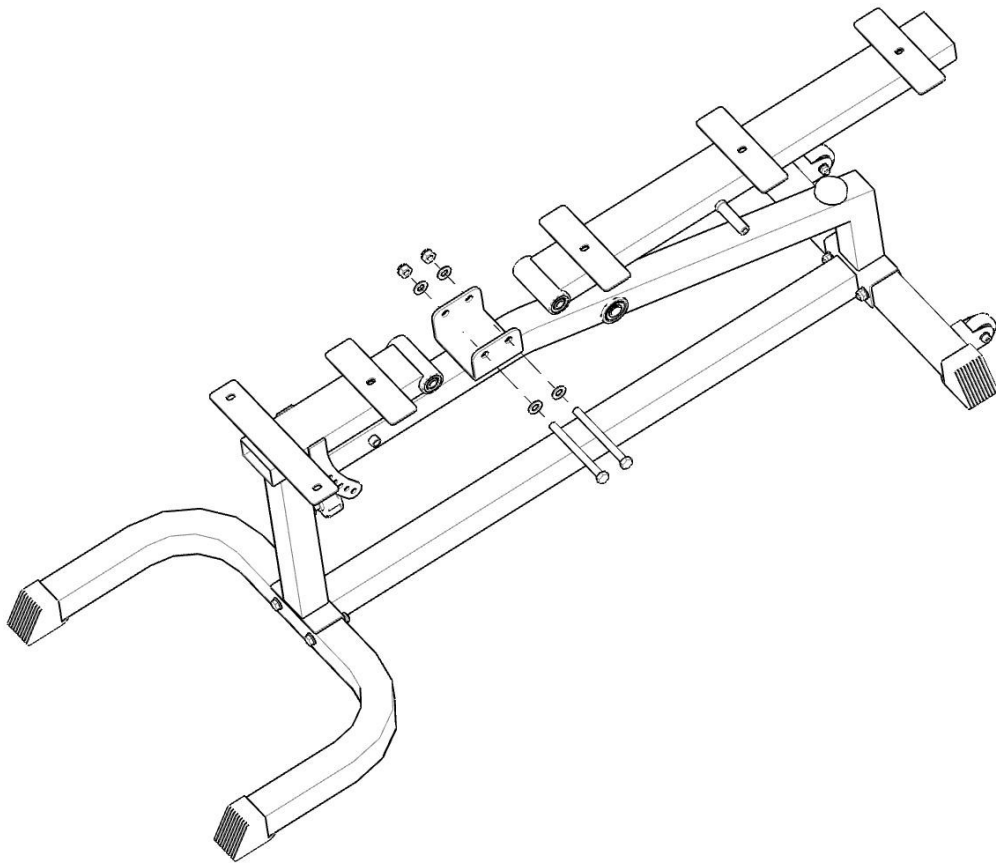
Figure 4

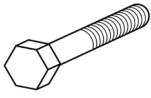

Step 4



		
M12*130----- 2pcs	M12 ----- 4pcs	M12 ----- 2pcs

As shown in Figure 4, part 8 and part 9 are assembled onto part 5 using bolts ,gaskets and nuts.

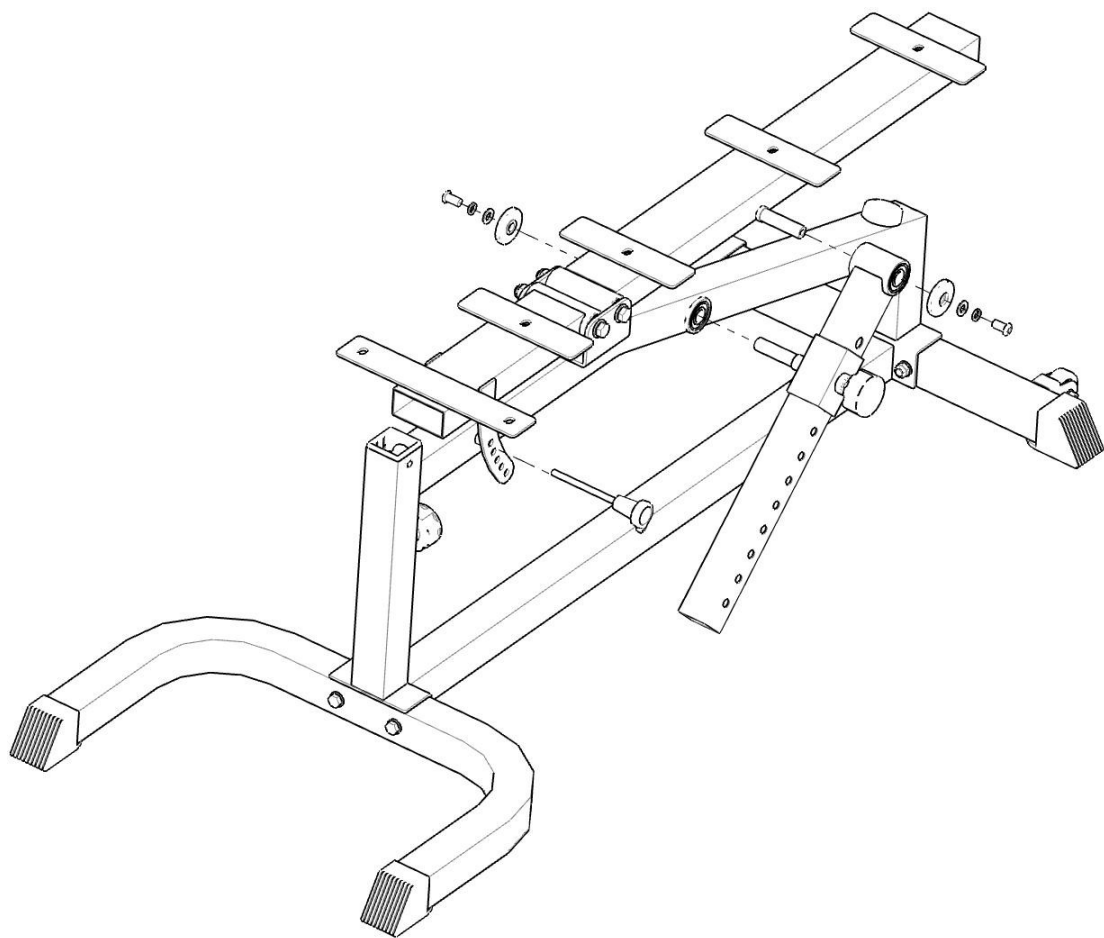
Figure 5

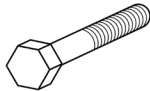

Step 5



	
M10*20-----2pcs	M10-----2pcs

As shown in Figure 5, part 10 and part 11 are assembled onto part 5 and part 9 using bolts and gaskets.

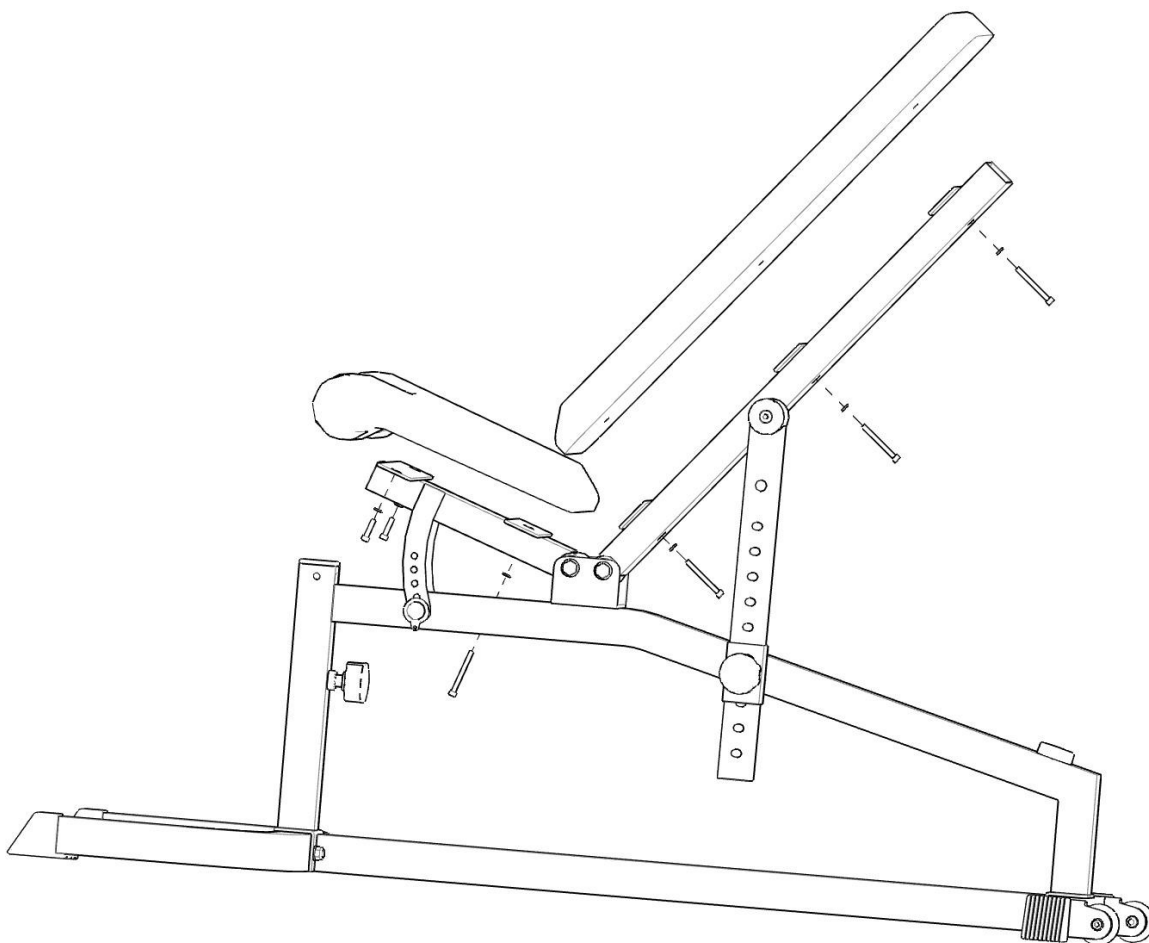
Figure 6

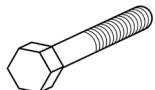
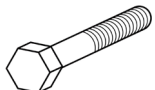

Step 6

		
M6*25 -----2pcs	M6*60 ----- 4pcs	M6 ----- 6pcs

As shown in Figure 6, part 13 and part 13 are assembled onto part 9 and part 8 using bolts and gaskets.